

Ordering Code: LR31XX-X-X-XX-XXX

Example: LR3113-2-N-4ST-10

Description: LR3100 Series Relief Valve, Buna Seal, Brass Body, Internal Poly Poppet, 7/16-20 Male SAE x Vent, 10 PSI open

<u>Series</u>	<u>O-ring</u>	<u>Body Material</u>	<u>Poppet Material</u>	<u>Connection</u>	<u>Crack Pressure</u>
LR3100	13 - Buna	2 - Brass 5 - 303 SST	N - Nylon P - PolyPro	1M - 1/8" Male NPT x Vent 2M - 1/4" Male NPT x Vent 3M - 3/8" Male NPT x Vent 4M - 1/2" Male NPT x Vent 6M - 3/4" Male NPT x Vent 4ST - 7/16 - 20 Male SAE x Vent	.11-20 psi

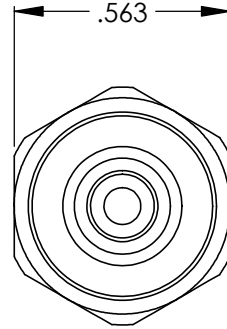
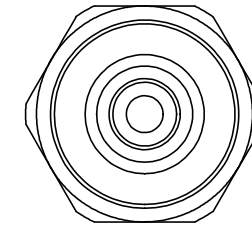
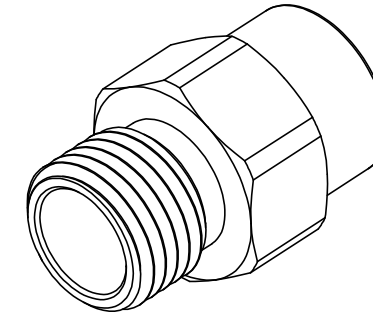

LR3100 Series - 4ST

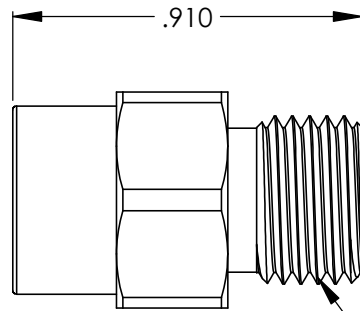

7/16-20 UN

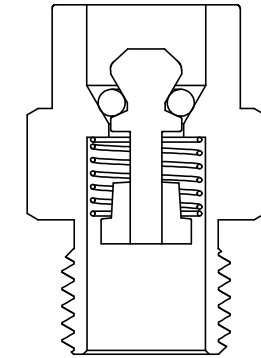
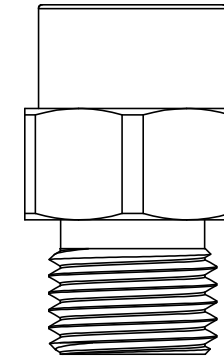

Body Material: Brass, 303 SST

Poppet Material: PolyPro, Nylon

O-ring Material: Buna-N

Spring Material: 302 SST - Any other spring materials consult factory

Operating Pressure: Vacuum to 60 psig (4.137 bar)

Cracking Pressure: .11 to 20 psig (.0076 bar to 1.379 bar) - Any crack pressure above or below standard crack pressure range consult factory

Connection Sizes: (1/8" MNPT to 3/4" MNPT), (4 SAE)

Note: Proper filtration is recommended to prevent damage to the o-ring or sealing surface

VALVE CHECK		
LR3100 Series Relief Valve		
SIZE B	Sales Drawing	REV A